



Systemkonzept eines modularen HiL-Systems für modellbasierte Funktionsentwicklung fahrzeugmechatronischer Systeme

Workshop der ASIM/GI-Fachgruppen, 09./10.03.2017, Ulm

Prof. Dr.-Ing. X. Liu-Henke
M.Eng. M. Göllner
Dr.-Ing. R. Buchta
M.Eng. F. Quantmeyer
M.Eng. H. Tao

Salzgitter

Suderburg

Wolfenbüttel & Braunschweig

Wolfsburg



1 Einleitung und Motivation

2 Grundlagen der Fahrsimulation

3 Mechatronische Entwicklungsmethodik

4 Systemkonzept

5 Realisierung und Anwendung

6 Resümee

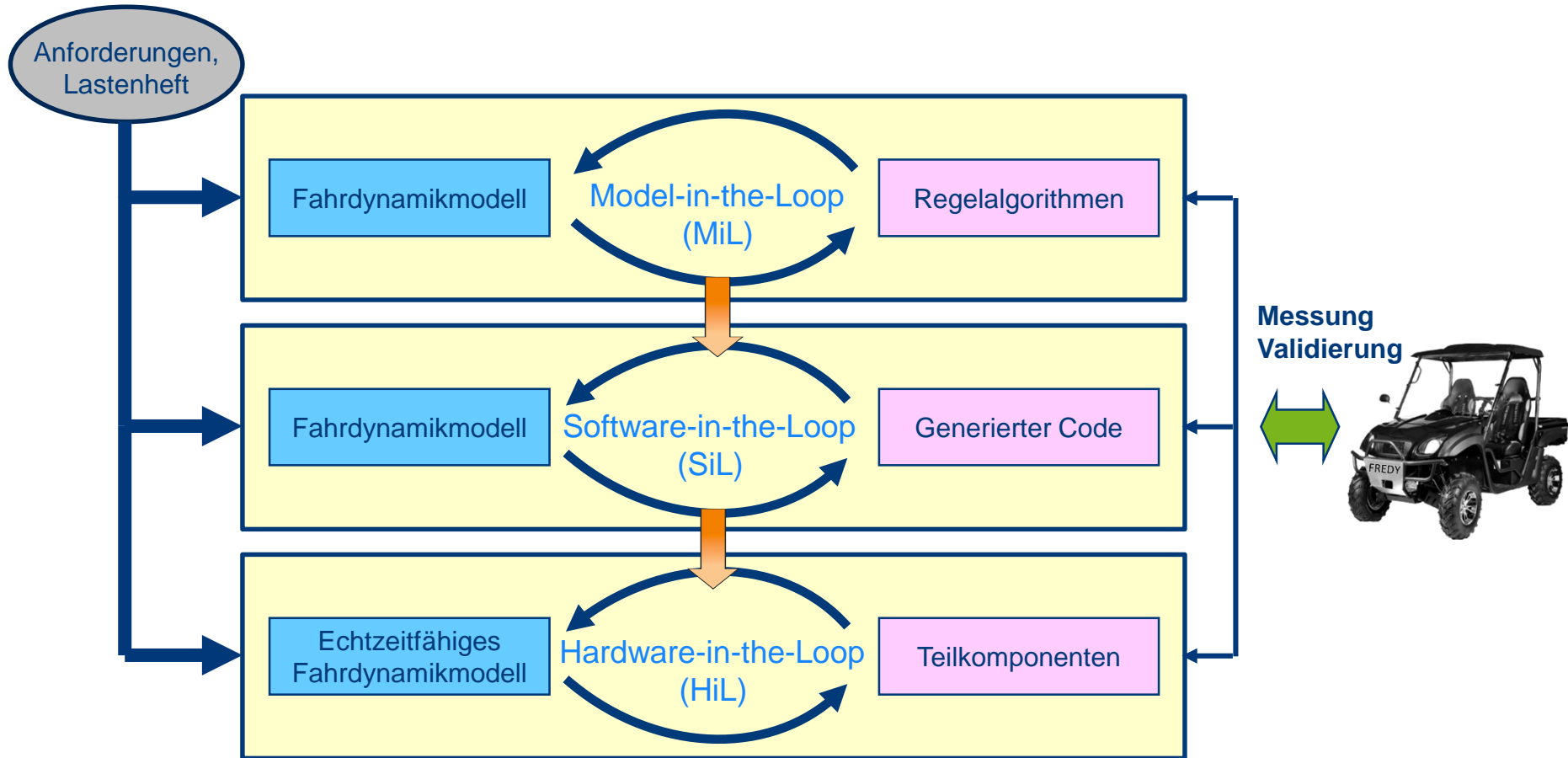

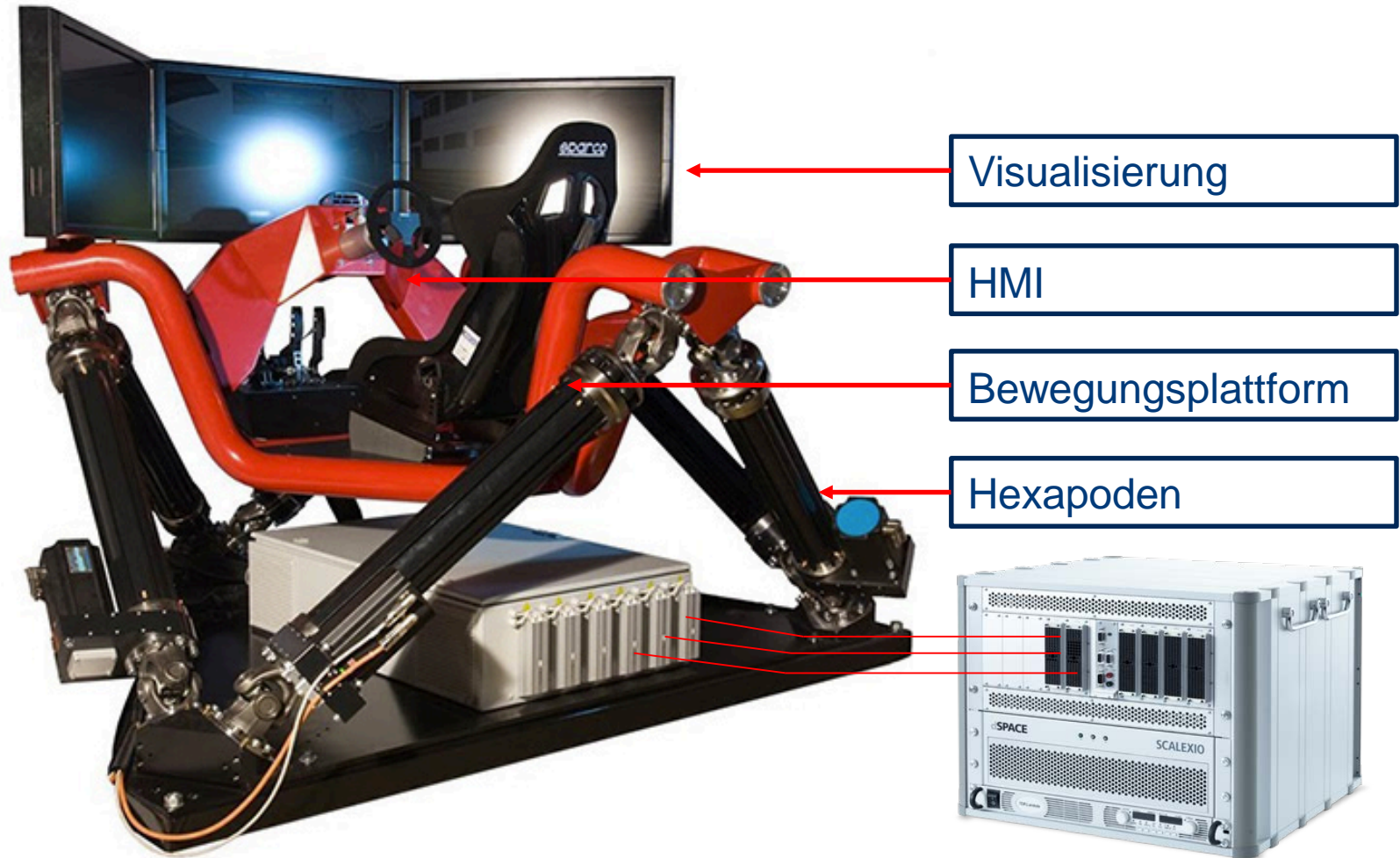



Fahrsimulation



Koppelbarkeit

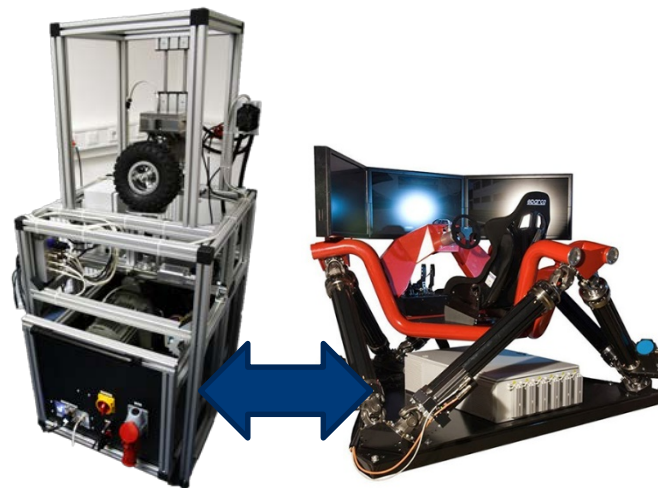

Anregungseinheit

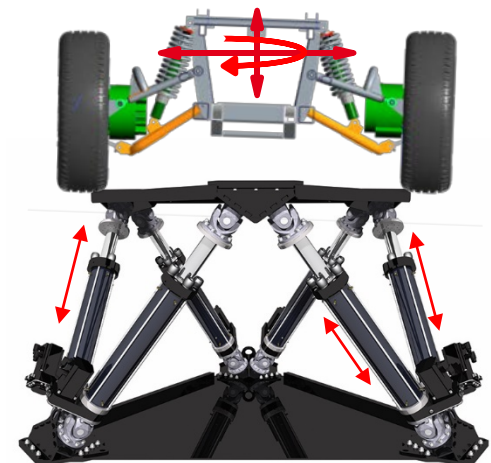

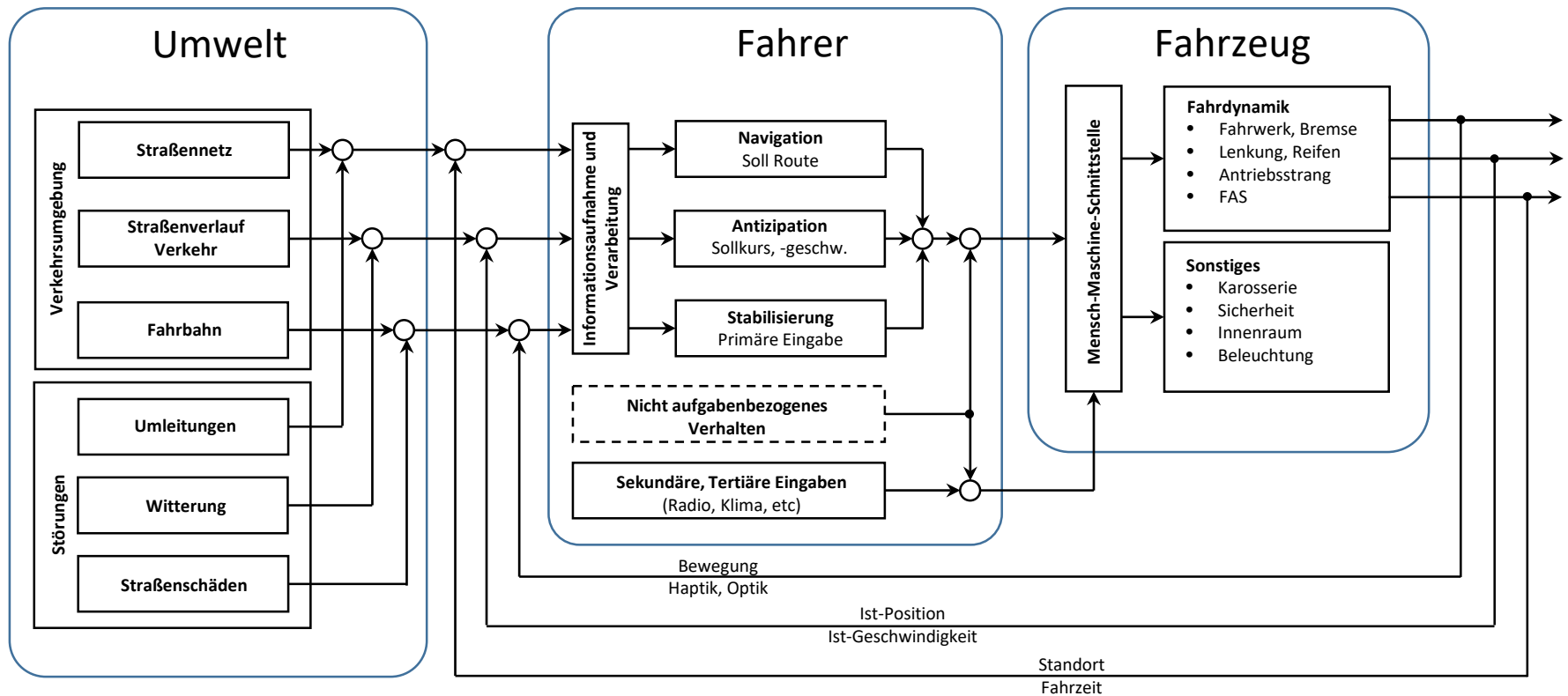

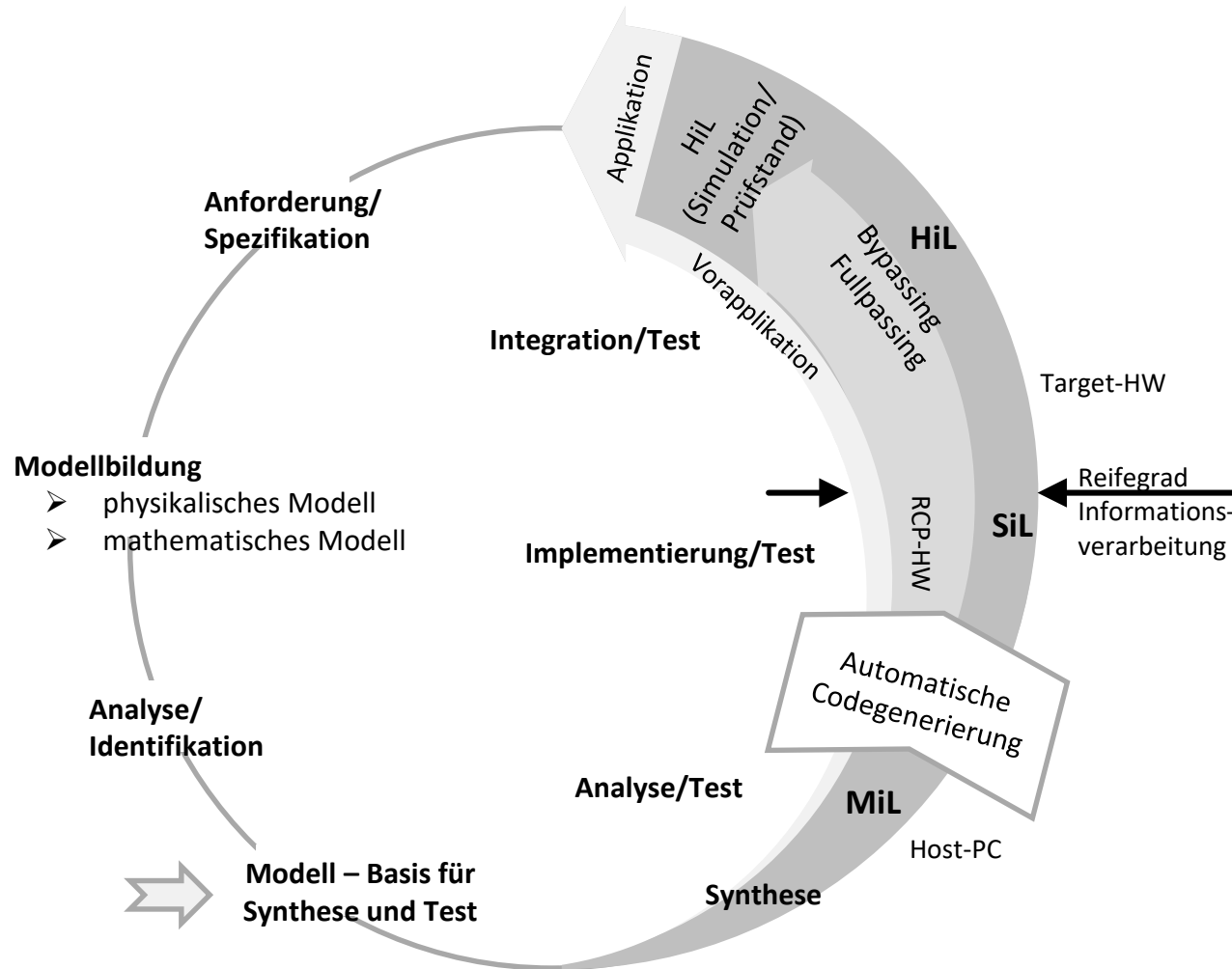

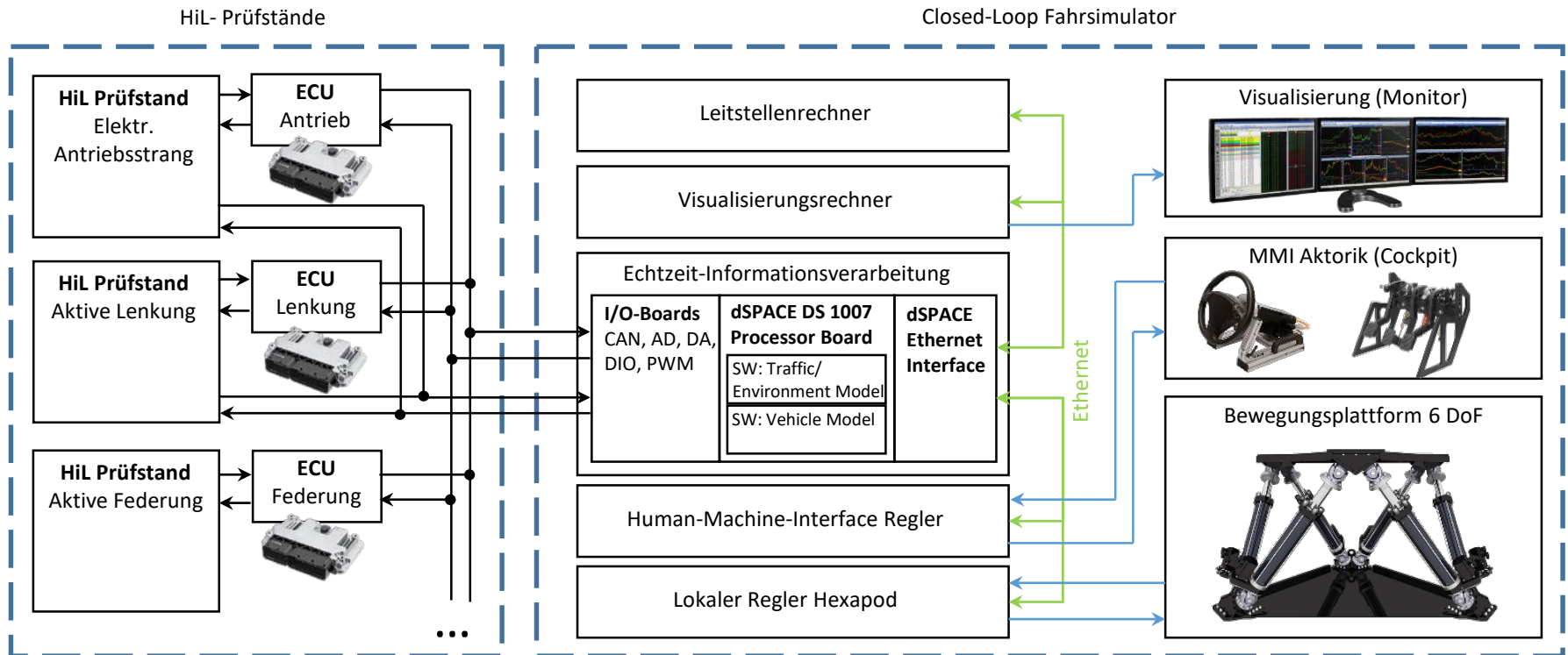

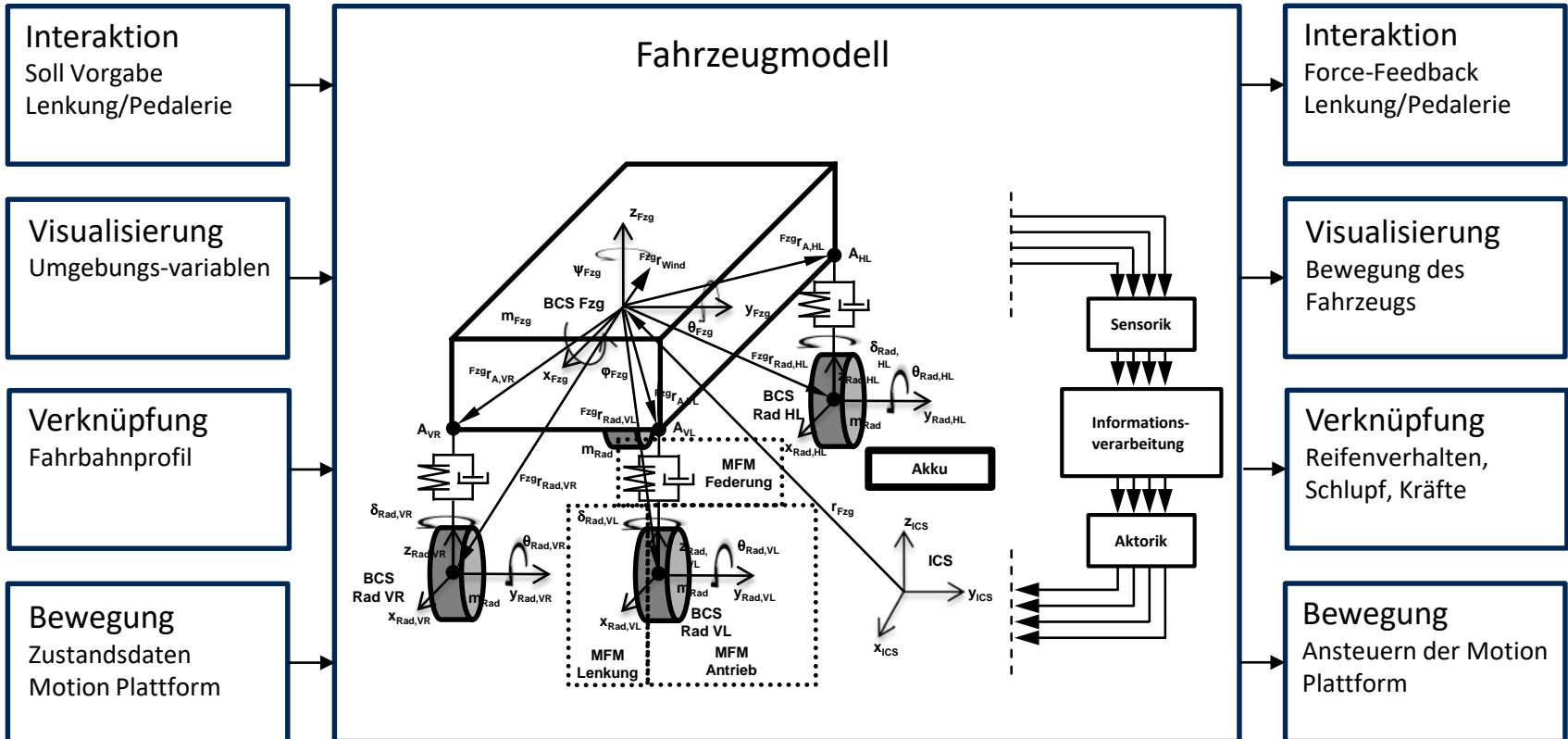



Wolfenbüttel & Braunschweig





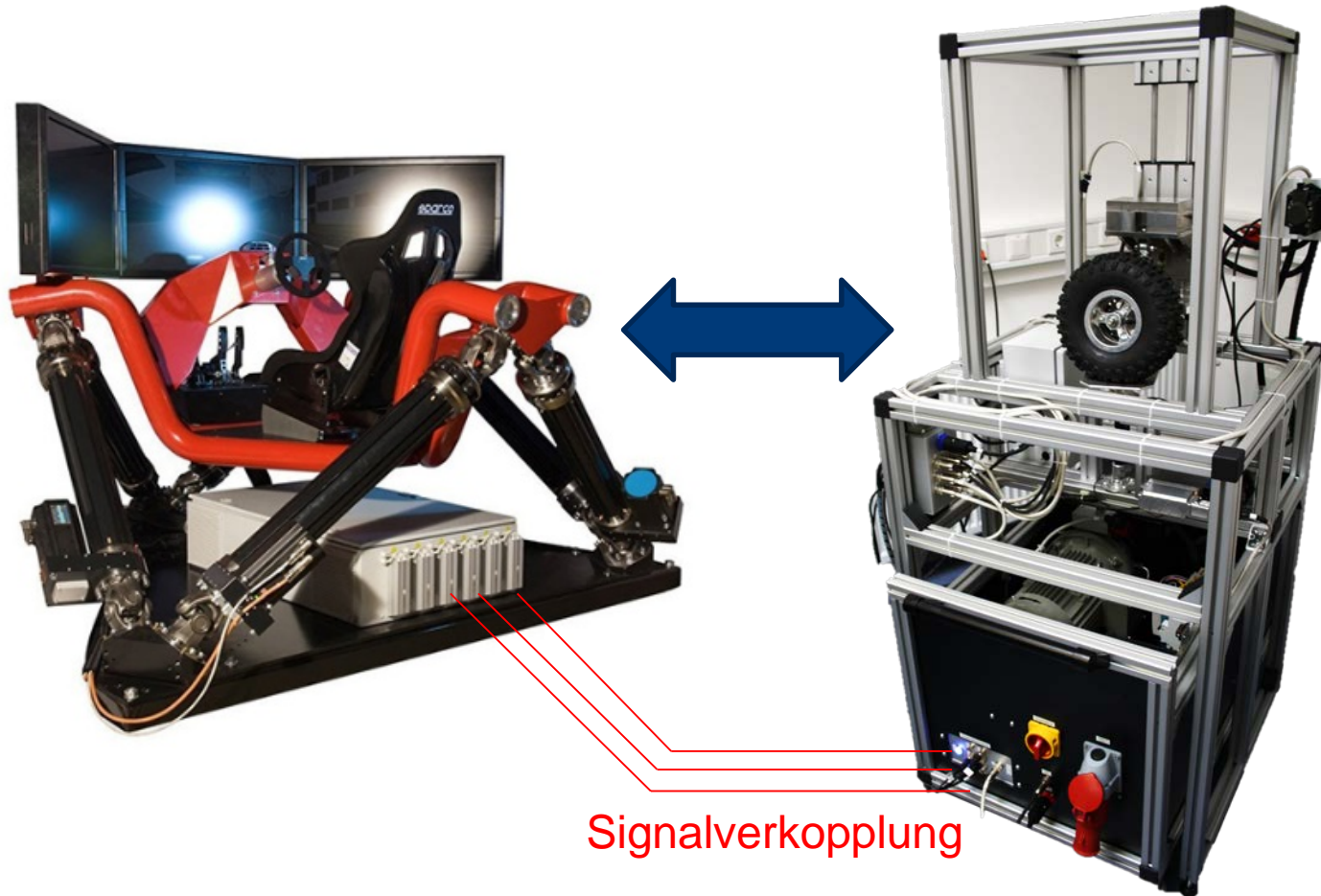

1. Test von Regelsysteme in virtueller Umgebung mit Driver-in-the-Loop
2. Visualisierung (Sichtsimulation) von Zuständen einer Open-Loop Simulation
3. Einsatz leistungsfähigster Echtzeitsysteme der Fa. dSPACE
4. Nutzung des Hexapoden als Anregungseinheit
5. Untersuchung von Fahrerpräferenzen mithilfe von haptischen Bedienelementen zur Nachbildung eines realitätsnahen Fahrerverhaltens.

Ende



Vielen Dank für ihre Aufmerksamkeit